

INSTRUCTION MANUAL

for N100 Flat Port 50

PN# 37181

FORWARD

Thank you for your purchase of a NAUTICAM product.

At NAUTICAM, we pride ourselves in the ability to recognize the requirements of professional as well as amateur underwater photographers and fulfill them through the innovative designs of our products. We strive to achieve a high level of user-friendliness by allowing stress-free installation and easy operation of all important functions of the camera.

Each product is individually inspected and water pressure tested to ensure optimum quality.

Please read this manual carefully before using the product, this will maximize its performance as well as its lifetime.

PRECAUTIONS

After installation of the port combo, please make sure the O-ring (s) are free from debris and uneven surface issues.

A water-tight/vacuum test without the camera inside the housing is highly recommended after the changing of port and O-ring(s).

Do not use lubricants from other brands with the silicone rubber O-ring on this housing, only use the lubricant provided by NAUTICAM.

Discontinue use immediately should you notice any leakage.

Do not open the product in a wet or sandy environment. Protect the interior from moisture and debris in order to prevent malfunction or leakage.

Defective products should be shipped to our distributors for service, unauthorized disassembling and/or modifications could result in malfunction or leakage.

When travelling by air, do not travel with any port installed as this may lead to a pressure difference between the atmosphere and inside the housing.

WARRANTY

All NAUTICAM Products are warranted against any material and manufacturing defects for two years from the date of purchase for consumer use. This warranty only applies to products purchased from authorized NAUTICAM dealers and does not extend beyond the original retail purchaser.

To return your product for service, please contact your regional authorized service center(s). Please note that this warranty only applies when the product is purchased in the territory where the service center is located.

NAUTICAM does not hold responsibility for damage, of any nature, to any equipment used with and/or placed within our products.

NAUTICAM accepts no liability for any loss of captured images or the inability to capture images even if it is due to the malfunctioning of our products.

Unauthorized modifications and/or repairs of our products will automatically invalidate the warranty.

IDENTIFICATION OF PARTS

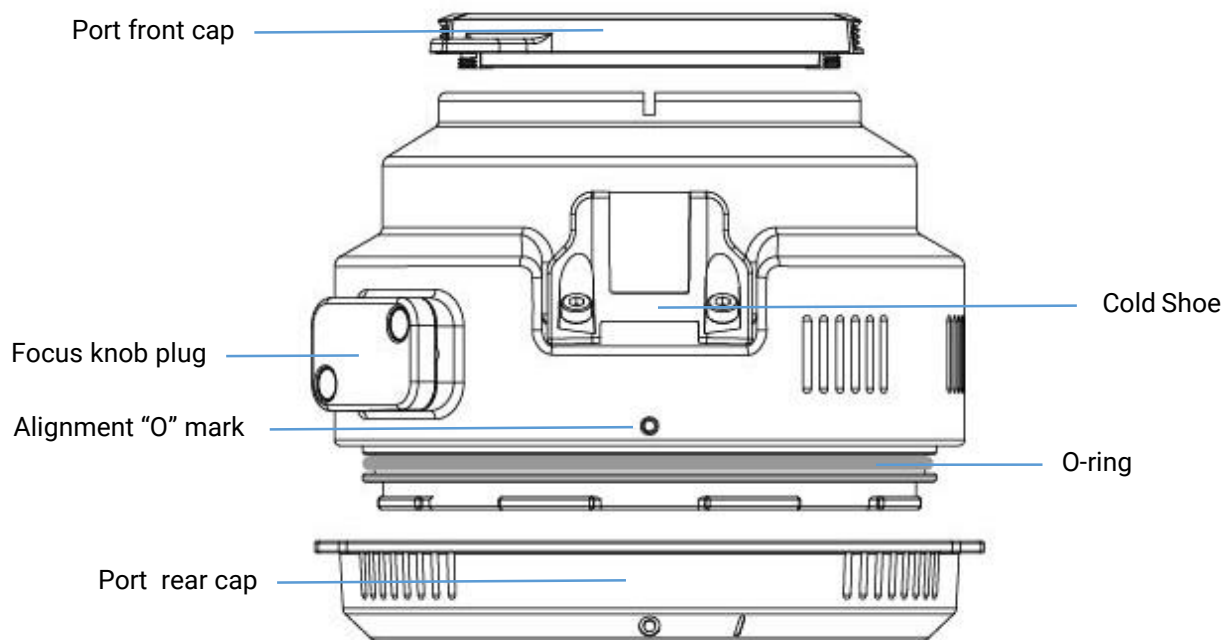

Preparation of the product

1. After verifying that the sealing O-ring is in good condition, lightly coat it with the lubricant provided and wipe away the excess.
2. Make sure the O-ring groove is free from any foreign material; the groove can be cleaned with the aid of a microfiber cloth.
3. Carefully place the port O-ring into the groove, ensuring that it lays flat and inside the entire groove.
4. Inspect the O-ring again, make sure there is no foreign materials.
5. After installing the port, lift up the entire system and inspect where the housing back and port meet the housing. There should be a thin, uniform gap with no extruded O-ring.

MOUNT PORT TO HOUSING

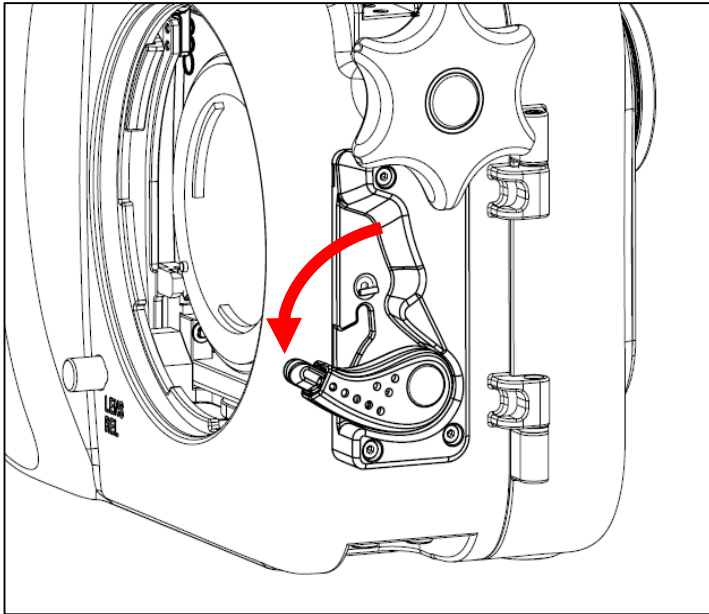

1. Turn the port locking lever of the housing to the release position as shown.

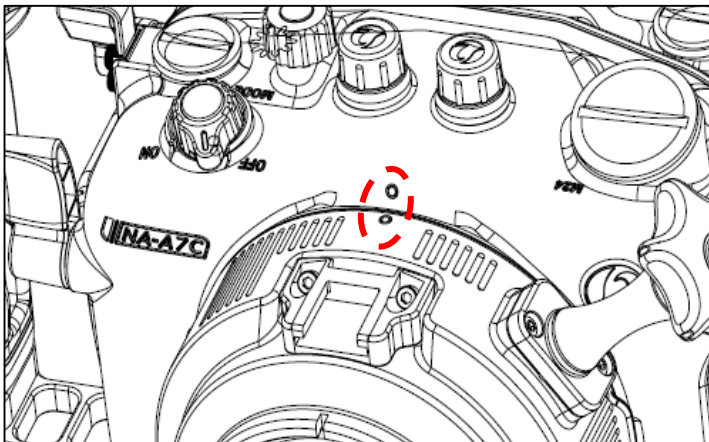

2. Align the "O" mark on the port with the WHITE dot on the housing. Gently push the port towards the housing until it cannot go any further.

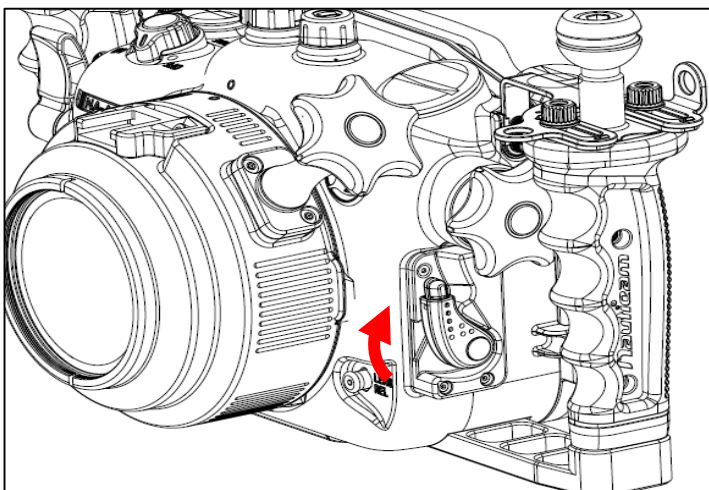

3. Lock the port into place by turning the port locking lever of the housing to the inward position. To ensure that the port is securely mounted, confirm that the green line on the safety button of the port locking lever is visible.

REMOVE FOCUS KNOB PLUG

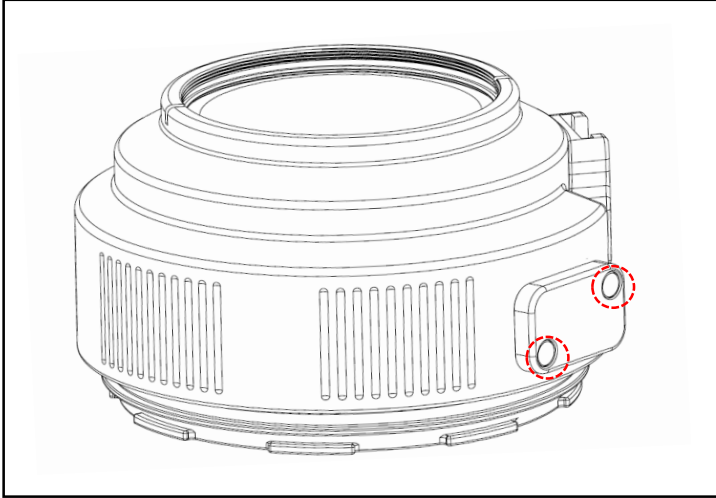

1. Remove the screw covers on the focus knob plug of the port

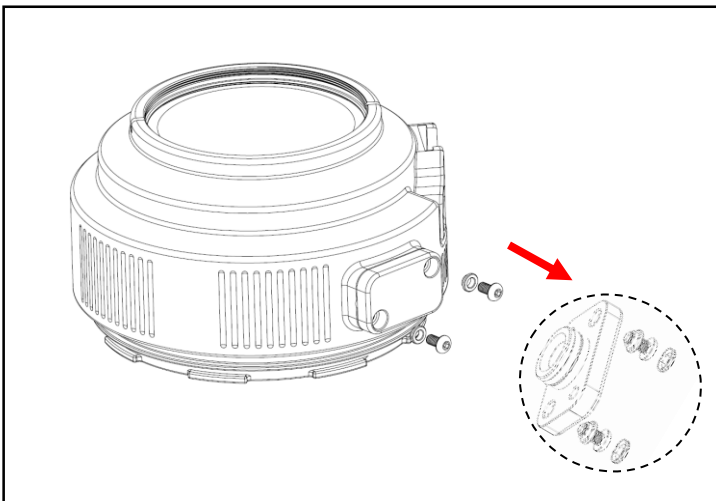

2. Remove the screws and focus knob plug from the port

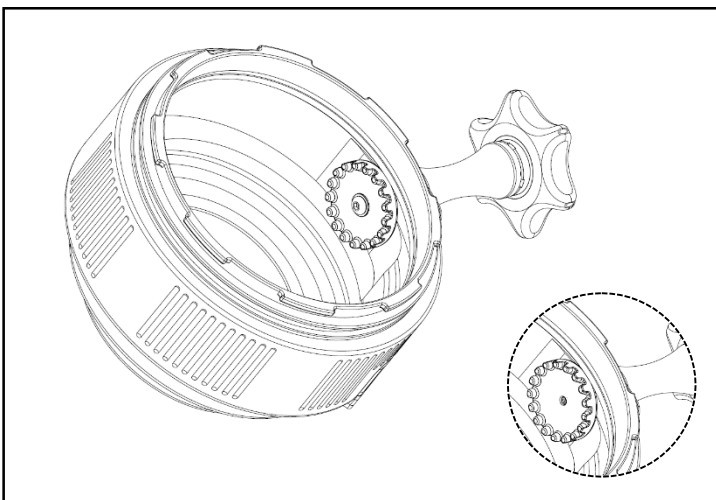

3. Install a focus knob on the port.

Please contact us for purchasing a focus knob and details on installation.

SPECIFICATIONS

37181 N100 Flat Port 50

Dimension (mm):	114.9×112.0×74.1
-----------------	------------------

Port Mount:	N100
-------------	------

Depth Rating:	150m
---------------	------

Remark:

Nauticam supports only e-manuals. Please download corresponding product manuals on google drive <https://bit.ly/Nauticammanual>, or contact us for e-manuals.

CARE AND MAINTENANCE

Soak the housing system in fresh water after each use, during which all control buttons/knobs should be operated a few times to avoid the accumulation of salt residue; wipe the housing with a towel before opening.

After removing the housing from the rinse tank, carefully press the housing lock safety button for a few times to avoid the accumulation of salt residue.

After each day of diving, it is advisable to have both the housing main O-ring and port O-ring removed from its groove with the O-ring remover and inspected for damage. Also check that the O-ring retains its original circular shape; never stretch the O-ring excessively or remove it with a sharp object. The O-ring groove should be cleaned to ensure it is free from any salt deposit or foreign material; lightly coat the O-ring with the provided lubricant before reinstalling it in the groove. A damaged O-ring should be discarded immediately and replaced only with one that is provided by NAUTICAM.