

## WFH TG-Pro

### Operation Manual for Dive Housing

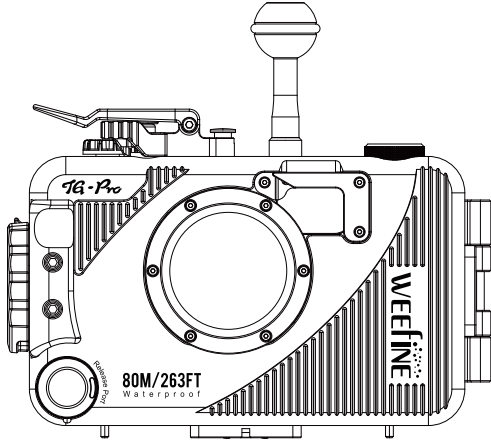

Please read this Manual carefully before use and keep it for future reference

### Product introduction

WEEFINE WFH TG-Pro Dive Housing is an upgrade of Weefine's WFH-TG6. It is a professional waterproof camera shell created specifically for underwater photographers. The front shell and back shell of the product are hard oxidized with black aluminum alloy, and the water-resistant depth can reach 80m; the product is equipped with an automatic vacuum-pumping system to detect its waterproofness by detecting the internal sealing performance. In addition, it can be connected with external display (M16 thread interface), and it allows the camera to be charged (Weefine's patent for invention), which greatly improves its usage time.

1. Weefine's patented design, "automatic vacuum-pumping system" is provided, which can be used to detect whether the product is sealed before the user enters the water. Its detection feedback allows users to know the waterproofness of the product all the time and makes them relieved with no need to worry about the risk of leakage.
2. The product is equipped with M16×0.75 thread interface, which allows the connection of an external display through the camera's HDMI interface. The external display with large sight window makes it easier for users to view and correct the current shooting picture, so that they can take more perfect photos and videos.
3. The product is equipped with an 18650 battery, which can supply power to the vacuum-pumping system and charge the camera through its built-in 5V power supply system. The camera can last more than 6 hours under normal shooting conditions.

### Product features

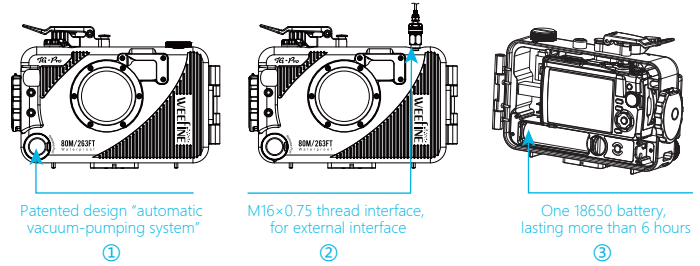

### Description of components

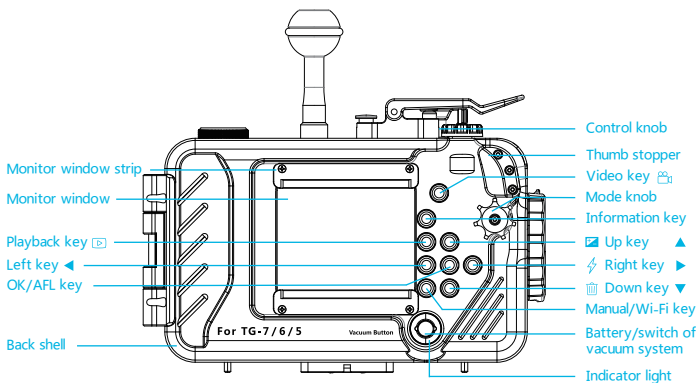
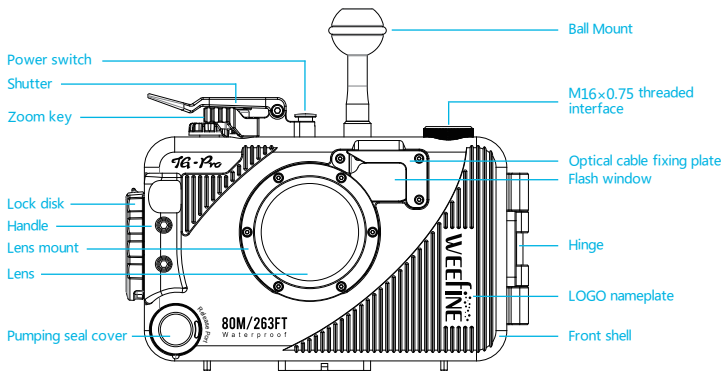

### Operating instructions

#### Startup/shutdown

In the off state, long press the key for 1 second to turn on the power and make the power indicator on ;  
In the on state, long press the key for 3 seconds to shut it down.

#### Battery indicator and vacuum-pumping system

The indicator light of the product is used both for power status and vacuum detection status; it indicates the percentage of battery level within the first 5 seconds after startup; it then indicates vacuum detection status after going off for 2 seconds.

Indicator light	Battery level
Blue light	80~100%
Green light	30~80%
Red light	10~30%
Red light flashing	<10%

#### Vacuum detection function

After startup, Press the button to start pumping. When the pumping is completed, the air pump will automatically stop.

Indicator light	Pressure in the shell	Working state
Red light flashing	Ordinary pressure	Pumping or intaking disabled
Red and green lights flashing alternately	Pressure change	Pumping or intaking
Green light flashing	Negative pressure	Pumping completed and sealed

#### 5V power output control

In the on state, long press the key for 1 second to switch the 5 V power output status: cycling (on-off).

#### Installing optical cable and remote control

Weefine's dedicated optical cable WFA76/WFA78 should be used. Insert the WFA76/WFA78 in the optical cable fixing plate on the waterproof shell, and connect the other end to the external flash, then the external flash can be triggered.

#### Replacing with body spare O-ring

Since the shell needs to be opened frequently to take out the camera, the main O-ring of the back shell is easy to stick to debris, making it dry and unlubricated. Therefore, the O-ring needs regular maintenance. If it is found damaged, replace it with the spare O-ring ;

#### How to replace it with the spare O-ring

First pick out the O-ring on the body with the disassembly tool, and then install the spare O-ring on the back shell (spare O-ring should be lubricated).

## Opening and closing waterproof shell

### Opening waterproof shell:

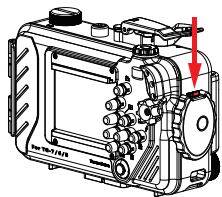

1. Press the latch.

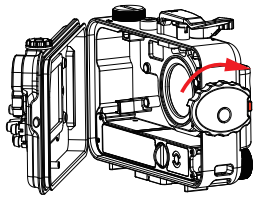

2. Turn the lock disc 90° clockwise to the position that can be opened.

### Closing waterproof shell:

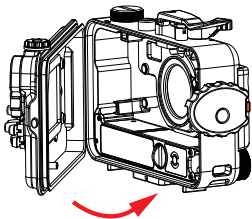

1. Close the waterproof shell in alignment with the notch of the lock disc.

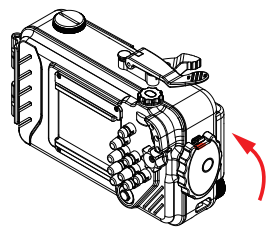

2. Turn the lock disc 90° counterclockwise to the position that can be locked.

## Mounting camera

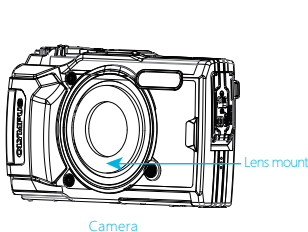

Camera

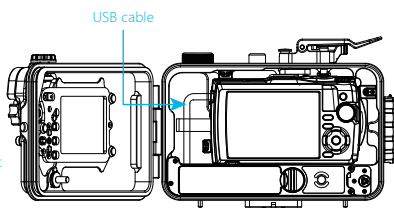

1. Insert the USB cable into the charging interface of the camera ;
2. Place the camera in the waterproof shell as shown ;
3. Close the waterproof shell and check that all controls of the shell are used correctly.

④

\* The lens mount must be removed before mounting the camera in the waterproof shell.

## Accessories in package

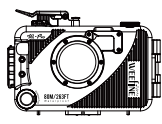

WFH TG-Pro x1



Operation Manual x1



Guarantee Card x1



HDMI-DD-C3 x1

WFA76 x1



Adapter board x1



Ball head x1



Hand strap x1



Spare O-ring x1



Silicone oil x1



Hex wrench x1



Disassembly tool x1

## Specification

Applicable camera	OLYMPUS TG7 / TG6 / TG5 camera
Display window	Hardened PC
Battery	One 18650 battery WBL-11N
Water-resistant depth	80m/264ft (IP68)
Threaded interface of lens	M52x0.75
External thread	M16×0.75 (for external interface)
Material	Aluminum alloy
Surface treatment	Hard anodizing
Dimension	185.9x75x128.2mm
Weight	1155g (with camera + battery on the land) 300g (with camera + battery underwater)

⑥

## Battery installation and use

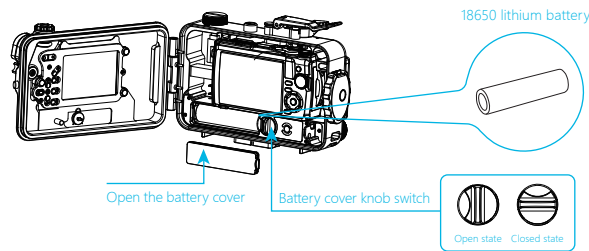

1. Turn the battery cover knob to the open state, then open the cover and install an 18650 lithium battery (notice the positive and negative electrodes).
2. Close the battery cover and turn the knob to the closed state.

\* Make sure the lithium battery is full.

## Checking waterproof shell

Check the main waterproof O-ring to ensure that there is no debris, broken filament, damage, or indentation.

### Water leakage function detection

1. Before use, unscrew the pumping seal cover, and then press the vacuum system switch for pumping. The indicator flashes between red and green when pumping; the green light flashes and the motor stops, indicating that pumping is completed; then tighten the pumping seal cover.
2. Put the waterproof shell on the land for 30 minutes. After that, if the water leakage detection indicator flashes green, the shell is properly sealed, and it can then be used in the water.

- The red light flashes before pumping
- The red and green lights flash alternately during pumping
- The green light flashes after pumping

3. If the red and green lights still flash alternately after pumping, then the waterproof shell is poorly sealed and it must be checked before use.

4. Before open the waterproof shell after use, open the pumping seal cover and press the air release valve to inject the air.

\* Attention: Be sure to tighten the pumping seal cover before entering the water.

⑤

## Checking camera

Always check the camera before mounting it in the waterproof shell

### 1. Confirm the battery

Confirm the battery is loaded ;

### 2. Remove the hand strap the camera

If the camera is loaded without removing the hand strap, the hand strap may get caught between the camera gap and cause water leakage ;

### 3. Remove the lens mount from the digital camera and install it to the waterproof shell

## Product safety and Information

\* Do not disassemble the waterproof shell yourself to avoid damage caused by artificial disassembly which can not be repaired.

\* Do not place the waterproof shell in direct sunlight or high temperature environment for a long time.

\* If it is intended not to use the waterproof shell for a long time, remove the battery in time and store it in a dry and cool place.

\* Before use, it is necessary to carefully check the O-ring to ensure that it is not damaged, with no sand or other debris attached. The disassembly tool in accessories should be used to disassemble the waterproof ring for cleaning. Do not disassemble it with sharp tools to avoid damage. Do not clean it with organic solution to avoid aging and deformation.

\* Always use original lubricants and original O-rings.

\* Do not open the waterproof shell when used underwater.

\* After leaving the water; be sure to wipe off the water on the surface of the waterproof shell before opening it, so as to avoid beads on the shell entering the interior and damaging the internal parts.

\* After use, be sure to shake the waterproof shell in fresh water and soak it for 30 minutes to remove the salt and impurities attached to the diving recorder and avoid corrosion and rust of metal parts on the waterproof shell. If the parts are rusted due to not cleaned after use, which affects the waterproofness and leads to water leakage, the cost of maintenance must be borne by the user.

## Quality assurance

We guarantee against the manufacturer's defects for 1 year from the date of purchase ; the manufacturer's defects occurring within 15 days from the date of purchase resulting in the replacement of the seller's products, as well as all other manufacturer's defects occurring within 1 year from the date of purchase can be repaired free of charge.

The warranty excludes the following circumstances:

1. Damage caused by failing to use, maintain and store the product in accordance with the operation manual ;
2. The product is repaired or altered by unauthorized service office or personnel ;
3. Damage caused by force majeure, e.g., geological disaster, war, etc.

⑦